



Inline mixed-flow fan Turbo

APPLICATION

Mixed flow fans are specially designed for supply and exhaust ventilation of premises requiring high pressure, powerful air flow and low noise level. These fans are featured with wide capabilities and high performance of axial and centrifugal fans. The fans are compatible with Ø 100 to 315 mm.

AREAS OF APPLICATION

Best Solution for Ventilation of hotel bathrooms / green house with temperature sensor and other humid premises as well for ventilation of residential premises, flats, cottages, offices, shops, cafes, health care and child care facilities etc.

DESIGN

- The fan Casing made of low-flammable polypropylene.
- Unique casing design where special clamps with latches permits easy dismantling of the impeller and motor block without dismantling the air duct. This makes the fan maintenance fast and easy.



- The ventilation unit with terminal box can be turned to any position.
- The inlet spigot is equipped with a collector to enable smooth air inlet to the fan. The hemispheric impeller shape and specially profiled blades increase the air flow circular velocity and provide higher pressure and capacity as compared to standard axial fans.
- The diffuser, the specially profiled impeller and the directing vanes at outlet from the fan casing distribute air flow in such a way as to attain the best combination of high performance, enhanced pressure and low noise.

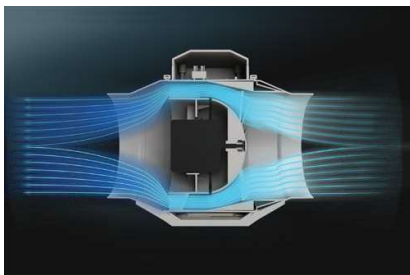

MOTOR

- Mixed flow fans are equipped with double-speed single phase motor on ball bearings with low energy demand.
- Motor equipped with built in thermal overload protection.
- Maintenance-free ball bearings for 40 000 hrs non-stop operation.
- Motor has IP X4 ingress protection rating.

SPEED CONTROL

- The built-in switch (option US) or external switch for multi speed fans (available upon separate order) are used to select one of two capacity modes.
- Smooth speed control is possible with a built-in speed controller (option FR) or an external thyristor speed controller (available upon separate order).

MOUNTING

- Due to compact design the fan is the ideal solution for mounting in limited spaces, including space behind a false ceiling.
- The fan can be installed in any section of the ventilation system from intake to the end of the ductworks.
- Wall or ceiling mounting with a mounting plate.
- TD – mounting kit for installation of one diameter fans in parallel (for boosting capacity)
- TL – mounting kit for installation of one diameter fans in series (for boosting pressure).



- Modifications and options
- T – adjustable run-out timer regulated from 2 to 30 minutes.
- US – three-position speed switch integrated in the fan.
- FR – built-in smooth speed controller from 0 to 100%. The fan is supplied with a pre-wired power cable with IEC plug as a standard. The cable modification with a standard electric plug is also available (Fr1).



- G – smooth speed controller with an electronic thermostat and an external temperature sensor that is fixed on 4 m power cable. The fan is supplied with a pre-wired power cable with IEC plug as a standard.



The cable modification with a standard electric plug is also available (G1).

- GI – smooth speed controller with an electronic thermostat and a temperature sensor integrated into the air duct. The fan is supplied with a pre-wired power cable with IEC plug as a standard. The cable modification with a standard electric plug is also available (GI1).

The options G and GI are used for automatic speed control depending on indoor temperature. The best ventilation solution for premises requiring permanent temperature control as greenhouses, orangeries, hotel bath rooms etc.

- W – the fan is equipped with a pre-wired power cable and IEC plug as a standard. Modification with a standard electric plug is available (W1).
- max – high-powered motor.

OVERALL DIMENSIONS

Type	Dimensions [mm]					Weight [kg]
	D	D1	B	H	L	
Turbo 100	97	164	196	241	303	1,68
Turbo 125	123	164	196	241	258	1,79
Turbo 150	148	187	220	251	289	3,18
Turbo 200	199	209	239	261	295,5	3,8
Turbo 250	247	257	287	323	383	7,83
Turbo 315	310	323	362	408	445	11,7

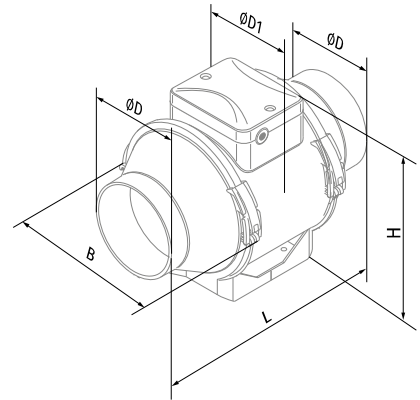

SPECIFICATIONS

Parameters	Turbo 100		Turbo 125		Turbo 150	
	min	max	min	max	min	max
Speed	1~ 230		1~ 230		1~ 230	
Voltage [V / 50 /60 Hz]	1~ 230		1~ 230		1~ 230	
Power [W]	23	25	25	29	42	50
Current [A]	0,10	0,11	0,11	0,13	0,19	0,22
Maximum air capacity [m³/h]	170	220	230	345	430	560
RPM [min ⁻¹]	1980	2545	1535	2265	1940	2620
Sound pressure level at 3 m distance [dBA]	27	32	29	34	32	44
Max. operating temperature [°C]	60		60		60	
Motor Protection	IP 44		IP 44		IP 44	
ErP	-		-		2018	

TURBO 100

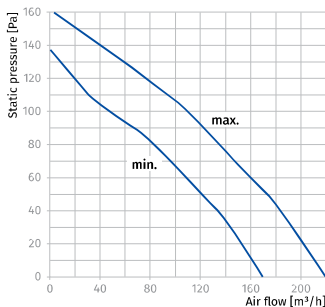

TURBO 125

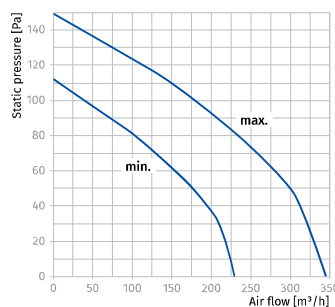

TURBO 150

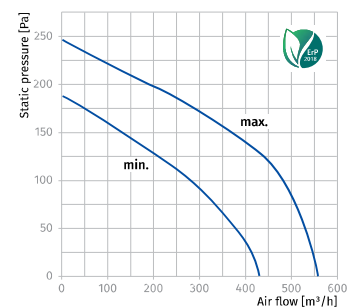

Sound power level, A-weighted	Total	Octave Frequency Bands [Hz]							LpA 3 m	LpA 1 m	
		63	125	250	500	1000	2000	4000			8000
L _{WA} to input [dBA]	54	19	35	50	49	44	37	25	17	33	43
L _{WA} to output [dBA]	53	17	34	50	49	48	36	24	17	32	42
L _{WA} to environment [dBA]	47	14	29	43	43	39	33	22	15	27	37

Sound power level, A-weighted	Total	Octave Frequency Bands [Hz]							LpA 3 m	LpA 1 m	
		63	125	250	500	1000	2000	4000			8000
L _{WA} to input [dBA]	54	26	38	52	50	44	38	27	17	34	44
L _{WA} to output [dBA]	54	25	37	51	49	43	38	28	18	33	43
L _{WA} to environment [dBA]	49	21	32	46	45	40	35	25	16	29	39

Sound power level, A-weighted	Total	Octave Frequency Bands [Hz]							LpA 3 m	LpA 1 m	
		63	125	250	500	1000	2000	4000			8000
L _{WA} to input [dBA]	59	31	45	54	52	54	48	35	29	38	48
L _{WA} to output [dBA]	63	37	49	56	56	60	48	39	30	42	52
L _{WA} to environment [dBA]	52	21	30	48	43	45	42	34	23	32	42

SPECIFICATIONS

Parameters	Turbo 200		Turbo 250		Turbo 315	
	min	max	min	max	min	max
Speed						
Voltage [V / 50 /60 Hz]	1~ 230		1~ 230		1~ 230	
Power [W]	76	108	125	177	227	315
Current [A]	0,34	0,48	0,54	0,79	0,99	1,42
Maximum air capacity [m³/h]	805	1080	1070	1360	1420	1750
RPM [min ⁻¹]	1915	2380	1955	2440	2115	2505
Sound pressure level at 3 m distance [dBA]	39	45	44	51	41	52
Max. operating temperature [°C]	60		60		60	
Motor Protection	IP 44		IP 44		IP 44	
ErP	2018		2018		2018	

TURBO 200

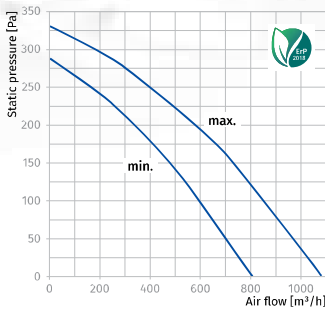

TURBO 250

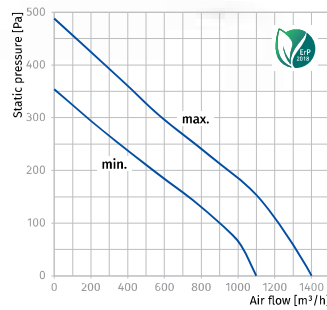

TURBO 315

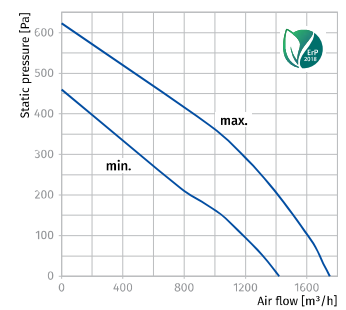

Sound power level, A-weighted	Total	Octave Frequency Bands (Hz)								LpA 3 m	LpA 1 m
		63	125	250	500	1000	2000	4000	8000		
L _{wa} to input [dBA]	66	38	50	58	59	60	59	55	45	45	55
L _{wa} to output [dBA]	64	40	50	54	58	59	57	51	44	43	53
L _{wa} to environment [dBA]	60	27	42	49	54	55	54	46	34	39	49

Sound power level, A-weighted	Total	Octave Frequency Bands (Hz)								LpA 3 m	LpA 1 m
		63	125	250	500	1000	2000	4000	8000		
L _{wa} to input [dBA]	72	48	57	63	66	69	64	54	45	52	62
L _{wa} to output [dBA]	75	48	56	64	70	71	66	56	45	54	64
L _{wa} to environment [dBA]	65	32	51	57	61	59	56	45	32	44	54

Sound power level, A-weighted	Total	Octave Frequency Bands (Hz)								LpA 3 m	LpA 1 m
		63	125	250	500	1000	2000	4000	8000		
L _{wa} to input [dBA]	72	43	54	62	67	66	67	58	47	52	62
L _{wa} to output [dBA]	70	45	57	59	64	66	63	56	46	50	60
L _{wa} to environment [dBA]	62	28	51	53	57	57	54	46	36	41	51

INSTALLATION EXAMPLES

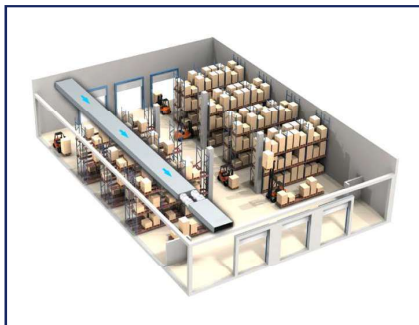

Warehouse Exhaust



Office Exhaust



Bathroom Exhaust